

Please read and save this Repair Parts Manual. Read this manual and the General Operating Instructions carefully before attempting to assemble, install, operate or maintain the product described. Protect yourself and others by observing all safety information. The Safety Instructions are contained in the General Operating Instructions. Failure to comply with the safety instructions accompanying this product could result in personal injury and/or property damage! Retain instructions for future reference.

# 1-Inch Dewatering Pump

Refer to form 1808-633-00 for General Operating and Safety Instructions.

## Description

These centrifugal pumps are engine-driven, self-priming (to 15 ft. lift), portable units, shipped completely assembled and mounted. A clog-resistant, open impeller is used to handle clear or dirty liquids, but is not intended for the handling of large solids. A built-in check valve assists in priming and a mechanical seal prevents leakage. All seals are Buna N. Applications include sprinkling, spraying, irrigation, draining, or general dewatering. Handle liquids from 40° to 180° F (4° to 82° C). For use with nonflammable, non-abrasive liquids, compatible with pump component materials.

## Specifications

Suction Inlet . . . . . 1"\*

Discharge Outlet . . . . . 1"\*

Dimensions . . . . . 13"H x 11"W x 13"L

Engine . . . . . 2 HP @ 5200 RPM/2 cycle

Weight . . . . . 18 lbs.

Basic Construction . . . . Aluminum with removable volute wearplate

Includes . . . . . 2 Garden hose adapters

(\* Standard NPT (female) pipe thread.

## Maintenance

**CAUTION** *This pump incorporates a 2-cycle engine as its driver. 2-cycle oil must be mixed with gasoline (24 parts gasoline to 1 part 2-cycle oil) to ensure performance and prevent severe engine damage. Refer to mixing instructions provided in the engine booklet and plates on the engine.*

**WARNING** *To prevent accidental starting always remove spark plug, or disconnect and ground spark plug wire before attempting to service or remove any component*

## Performance Chart

Suction Lift in Ft.	5psi	GPH of Water at Discharge Pressure in psi †					30psi	35psi	Max. pres. psi *
		10psi	15psi	20psi	25psi				
0 ft.	3600 gph	3350	3100	2760	2410	2040	1580	47psi	
5	3250	3050	2750	2450	2100	1700	1240	46	
10	2800	2600	2370	2100	1750	1350	830	44	
15	2400	2200	2000	1750	1420	1070	680	42	

(\* Shut off; to convert to head, multiply by 2.31.  
 (†) Does not include pressure losses in suction and discharge piping.

## MECHANICAL SEAL REPLACEMENT

Refer to Figures 1 and 2.

**IMPORTANT:** Always replace both seal seat (Ref. No. 5) and seal head (Ref. No. 4) to ensure proper mating of components!

1. Unscrew fasteners (Ref. Nos. 14 & 16) and remove pump casing (Ref. No. 12) and o-ring (Ref. No. 11) from adapter (Ref. No. 3).
2. Unthread fasteners (Ref. No. 8) and remove volute (Ref. No. 9) and flapper valve (Ref. No. 10) from adapter.
3. Unscrew impeller (Ref. No. 7) from engine shaft. Remove impeller shim (Ref. No. 6) from engine shaft.

**NOTE:** To keep shaft from turning, remove shroud from engine and hold flywheel in place. Impeller is screwed on to the right (CW). To unscrew, turn impeller to the left (CCW) when facing impeller.

4. Unthread fasteners (Ref. No. 17) and

remove adapter from engine mounting face.

5. Lay adapter face down on a flat, stable surface and press seal cartridge from adapter.
6. Pry seal seat from rear of impeller with a screwdriver or other suitable means. Clean recess in adapter for seal cartridge and recess in impeller for seal seat before inserting any new parts.
7. Inspect polished face (do not touch faces) of seal seat and polished face of seal head to ensure they are clean and not marred.
8. Press new seal head into recess in adapter. A sealing compound (such as silicon or Permatex) may be used to assure a water-tight fit on outside of seal head.
9. Wet rubber portion of seal seat with a light coating of soapy water.
10. Replace any impeller shims removed in disassembly (See Figure 1).
11. Press seal seat squarely into cavity in impeller. If seal seat does not press squarely into cavity, it can be adjusted in place by pushing on it with a piece of pipe, wooden dowel or the like. Always use a piece of cardboard between pipe and seal seat to avoid scratching polished face of seal seat. This is a lapped surface and must be handled very

# 1-Inch Dewatering Pump

## Maintenance (Continued)

carefully.

12. Secure adapter on engine mounting face.
13. Screw impeller back in place (CW), tightening until it is against shaft.
14. Remount volute, positioning o-ring in place.

**IMPORTANT:** Always inspect o-ring. Replace when cracked or worn. Wet o-ring and flapper valve with oil or Vaseline for ease of assembly.

15. Remount casing.

### SHIM ADJUSTMENT

1. When installing a replacement engine, adapter, impeller, shaft sleeve, volute or casing it may be necessary to vary the number of impeller shims (Ref. No. 6) that will be required. This is easily done by adding one shim more than was removed and reassembling the pump as described in MECHANICAL SEAL REPLACEMENT section.

**NOTE:** When adding or removing shims, it is best to proceed with a 0.010" increment each time. Remove spark plug wire from engine and ground. While tightening unit together turn shaft (by pulling on recoil starter, etc.);

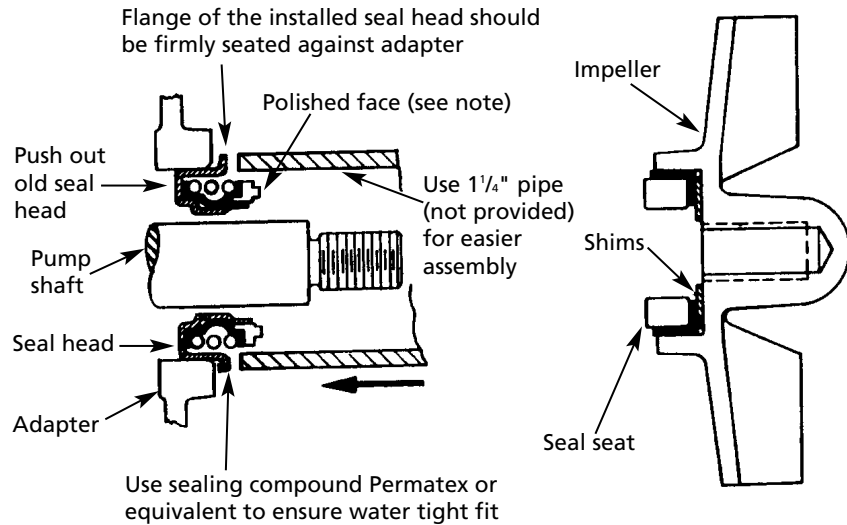

**Figure 1 – Mechanical Seal Replacement**

feel for shaft seizing. If shaft begins to seize before fasteners are completely tight, disassemble pump and remove one shim and repeat assembly.

2. Once having added one shim more than original, ensure that volute (Ref. No. 9) and adapter (Ref. No. 3) are firmly fitted (check fasteners Ref. Nos. 8 & 17). When engine turns freely add shims until it does strike, then remove a 0.010" shim. This should allow proper clearance.

3. Proper running clearance for impeller should be as close as possible to volute without striking; maximum clearance is 1/32" (0.032").
4. Follow above procedure until proper clearance is obtained. This will ensure maximum performance.

**For Repair Parts, contact dealer where pump was purchased.**

Please provide following information:

- Model number
- Serial number (if any)
- Part description and number as shown in parts list

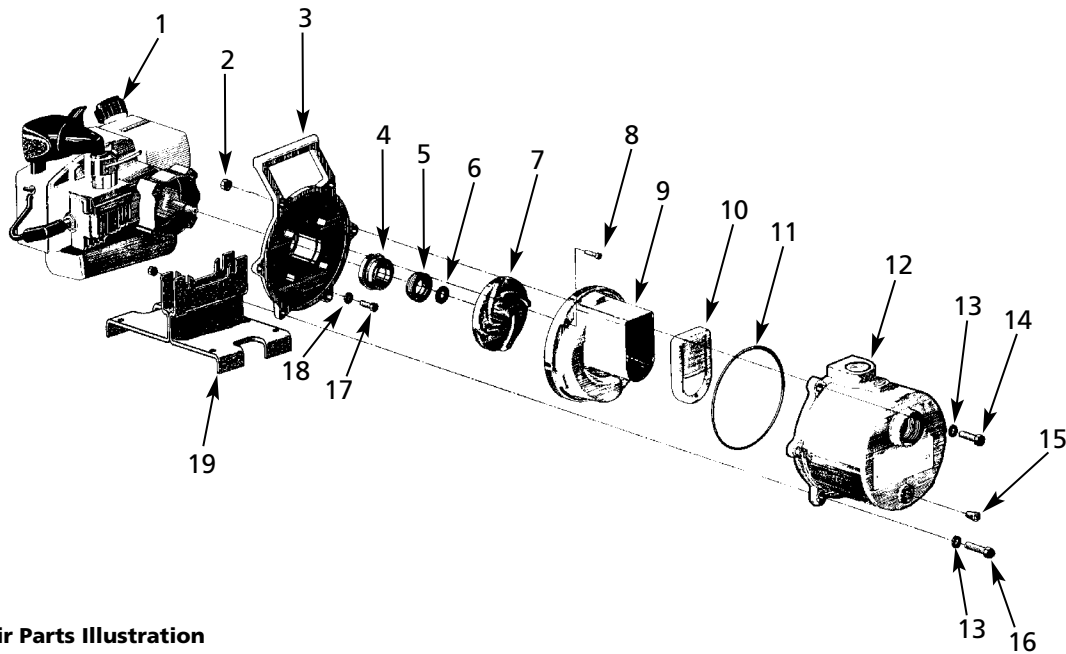

Figure 2 – Repair Parts Illustration

**Repair Parts List**

Ref. No.	Description	Part No.	Qty.
1	Engine	1634-075-00	1
2	Nut	*	6
3	Adapter	2221-002-01	1
4 & 5	Seal assembly - Buna N	1640-162-95	1
6	Impeller shims (1) 0.010, (1) 0.020, (1) 0.030	1806-040-90	1
7	Impeller	2221-003-01	1
8	Fastener	*	1
9	Volute	4380-150-01	1
10	Flapper valve	2221-006-00	1
11	O-ring	2221-009-00	1
12	Casing	4380-001-01	1
13	Washer	*	6
14	Fastener	*	4
15	Pipe plug	*	1
16	Fastener	*	2
17	Fastener	*	4
18	Washer	*	4
19	Base foot	4380-102-00	1
Δ	Garden hose adapter	1696-073-00	2
Δ	8 oz. 2-Cycle oil; 24:1 mix	4381-170-00	1
Δ	Roll of Teflon tape	1696-094-00	1

(\*) Standard hardware item - available locally.

(Δ) Not shown.

