

Please read and save this Repair Parts Manual. Read this manual and the General Operating Instructions carefully before attempting to assemble, install, operate or maintain the product described. Protect yourself and others by observing all safety information. The Safety Instructions are contained in the General Operating Instructions. Failure to comply with the safety instructions accompanying this product could result in personal injury and/or property damage! Retain instructions for future reference. AMT reserves the right to discontinue any model or change specifications at any time without incurring any obligation.

©2006 American Machine & Tool Co., Inc. of PA, A Subsidiary of The Gorman-Rupp Company, All Rights Reserved.

▲ WARNING Periodic maintenance and inspection is required on all pumps to insure proper operation. Unit must be clear of debris and sediment. Inspect for leaks and loose bolts. Failure to do so voids warranty.

2 Inch Dewatering Pumps

Refer to pump manual 1808-633-00 for General Operating and Safety Instructions.

Description

These dewatering pumps are engine driven, self-priming (to 20 ft. lift), portable units. Clog resistant impeller is capable of handling solids up to 3/8" diameter. For use with non-flammable, non-abrasive liquids compatible with pump component materials.

Specifications

Port Size 2" NPT
 Engine:
 4222 B&S 148 cc
 4223 B&S 206 cc
 4225 Honda GC 160
 Basic Construction Cast Iron
 w/Buna or Viton seal depending on model

Maintenance

▲ WARNING *To prevent accidental starting, always remove spark plug, or disconnect and ground spark plug wire before attempting to service or remove any component.*

MECHANICAL SEAL REPLACEMENT

Refer to figures 1A, 1B and 2.

IMPORTANT: Always replace seal assembly and shaft sleeve to ensure proper mating of mechanical seal components.

1. Unthread fasteners and remove casing from adapter.

NOTE: Inspect gasket. Replace if torn or damaged.

2. Unscrew impeller from engine shaft and remove impeller shims. Keep shims for assembly.

NOTE: To keep shaft from turning, remove shroud from engine and hold flywheel in place. Engine has a threaded shaft. To remove impeller, turn impeller CCW (facing engine shaft).

3. Slide shaft sleeve and seal head (the part with spring) from engine shaft.

4. Unthread fasteners and remove adapter from engine mounting face.

5. Push seal seat from adapter

recess with a screwdriver.

6. Clean adapter recess before inserting a new seal seat.

NOTE: The precision lapped faces on mechanical seal are easily damaged.

Handle your replacement seal carefully.

7. Carefully wipe polished surface of new seal seat with a clean cloth.

8. Wet rubber portion of seal seat with a light coating of soapy water.

9. Press new seal seat squarely into cavity in adapter. If seal seat does not press squarely into cavity, it can be adjusted in place by pushing on it with a piece of cardboard between pipe and seal seat. Avoid scratching seal seat. (This is a lapped surface and must be handled very carefully).

NOTE: Do not install a scratched, cracked or damaged seal seat; it will leak.

10. After seal seat is in place, ensure that it is clean and has not been marred.

11. Using a clean cloth, wipe shaft and make certain that it is perfectly clean.

12. Secure adapter on engine mounting face.

▲ CAUTION *Tighten fasteners EVENLY to avoid cocking adapter on rabbet on engine mounting face.*

13. Apply a light coating of soapy water to inside rubber portion of seal head and slide onto shaft sleeve. Slip shaft sleeve with seal cartridge onto engine shaft.

▲ CAUTION *Do not touch or wipe polished part of seal cartridge.*

14. Replace impeller shims.

NOTE: See shim adjustment below

15. Screw impeller back in place, tightening until it is against shaft shoulder.

16. Remount pump casing on adapter.

SHIM ADJUSTMENT

When installing a replacement impeller, it may be necessary to vary number of shims that will be required. This is done by adding 0.010" shim more than was removed and reassembling pump as follows:

IMPORTANT: When clearance between impeller and casing exceeds 1/16" at face of impeller or 1/8" on outside diameter of impeller, it may be necessary to take corrective action.

1. Ensure that casing is snugly in place and check shaft to make sure it is turning freely. If it turns freely, check to ensure that adapter and casing are seated firmly, compressing gasket where they meet. If they are not seated, tighten fasteners and recheck shaft for free turning. Tighten carefully, turning shaft while tightening. If shaft seizes before fasteners are completely tight, disassembly pump, remove one shim and repeat reassembly.
2. If at any time during shim adjustment shaft does not turn free, or a metal-to-metal rubbing can be heard or felt when turning shaft, repeat SHIM ADJUSTMENT procedure.

NOTE: Impeller must be as close as possible to casing in order to perform properly and retain suction capabilities.

For Replacement Parts, contact dealer where pump was purchased.

Please provide following information:

- Model number
- Serial number (if any)
- Part description and number as shown in parts list

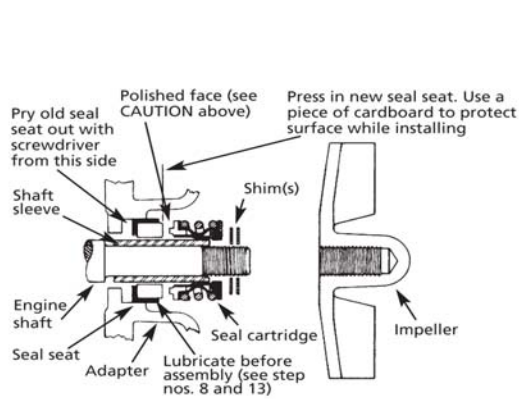

Figure 1A - Mechanical Seal Replacement

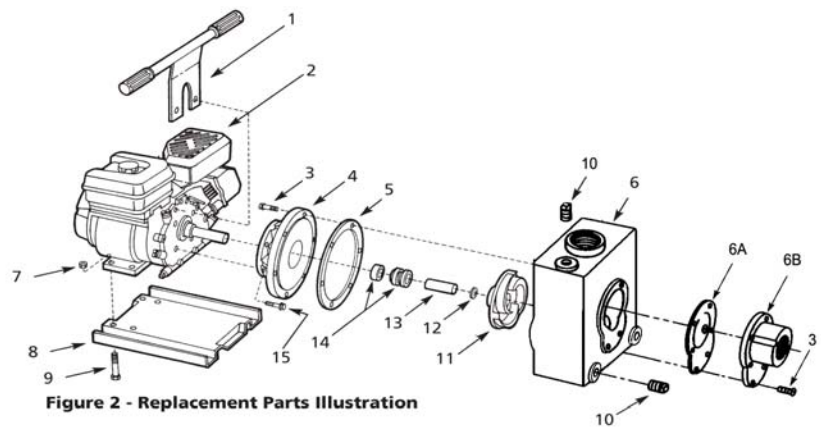

Figure 2 - Replacement Parts Illustration

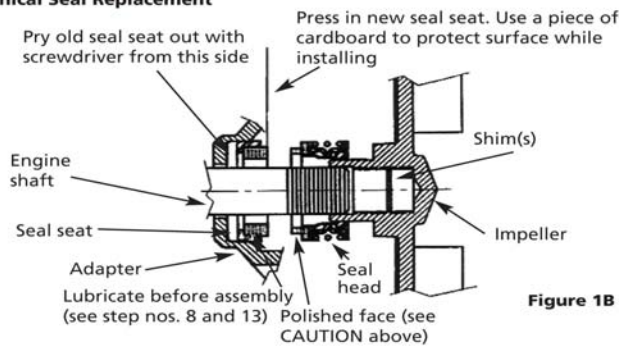

Figure 1B - Mechanical Seal Replacement

Repair Parts List

Ref. No.	Description	4225-95 & 4225-V5	4222-95 & 4222-V5	4223-95 & 4223-V5	Qty.
1	Carrying handle	1549-007-90	1549-007-90	1549-007-90	1
2	Engine	1632-042-00	1630-003-00	1639-034-00	1
3	Fastener	*	*	*	6
4	Adapter	1474-000-02	1474-000-01	1474-000-01	1
5	Gasket	See Ref. No. 14	See Ref. No. 14	See Ref. No. 14	1
6	Casing (includes 3, 6A, 6B and 10)	4220-001-V5	4220-001-V5	4220-001-V5	1
6A	Flapper Valve, Buna	1683-000-90	1683-000-90	1683-000-90	1
6A	Flapper Valve, Viton	1683-000-91	1683-000-91	1683-000-91	1
6B	Suction Plate	1487-000-01	1487-000-01	1487-000-01	1
7	Fastener	*	*	*	4
8	Base	4220-100-00	4220-100-00	4220-100-00	1
9	Fastener	*	*	*	4
10	Pipe Plug	*	*	*	3
11	Impeller	1493-012-02	1493-000-01	1496-002-01	1
12	Impeller shim set (Pkg)	3827-172-90	1658-000-90	1658-000-90	1
13	Shaft sleeve	Not Required	1483-000-00	1483-000-00	1
14	Seal kit - Buna N**	1006-999-BS	1007-999-B0	1007-999-B0	1
14	Seal kit - Viton®	1006-999-V0	1007-999-V0	1007-999-V0	1
15	Fastener	*	*	*	4

(*) Standard hardware item, available locally.

(**) Includes Ref. 5, 6A, 12, 13 and 14

NOTE: Pipe nipples are included with pump (not shown), Part No. 1696-044-00.