

Please read and save this Repair Parts Manual. Read this manual and General Operating Instructions carefully before attempting to assemble, install, operate or maintain product described. Protect yourself and others by observing all safety information. Safety Instructions are contained in General Operating Instructions. Failure to comply with safety instructions accompanying this product could result in personal injury and/or property damage! Retain instructions for future reference.

2-Inch Self-Priming Dredging Pump

Refer to form 1808-633-00 (engine-driven) or 1808-635-00 (pedestal mount) for General Operating and Safety Instructions.

Description

These dredging pumps are abrasion resistant, heavy duty, centrifugal, self-priming (to 20 ft. lift), portable units, shipped completely assembled and mounted. Pump is equipped with abrasion resistant high chromium steel, semi-open, solids handling impeller, replaceable volute, and wear plate. A built-in check valve assists in priming and a silicon-carbide mechanical shaft seal resists wear and leaking. Simple four bolt casing design for easy cleanout and wear part replacement. Handles liquids from 40° to 160° F (4° to 71° C). This pump is for use with nonflammable liquids compatible with pump component materials.

Specifications (Inches)

DRIVER			Max. Solid Dia.	PUMP Dimensions			Shaft Dia.	Keyway	Weight (lbs.)	Basic Construction
Model	Engine	HP		H	W	L				
316F-95	OHV Honda GX	5½	1/2"	19¾"	17¾"	22"	N/A	N/A	62	Cast iron & steel
316F-99	N/A (pedestal)	5 min.	1/2"	9	8	15¾"	3/4	3/16 x 1½	43	Cast iron & steel

Performance Chart

Pump Speed	GPH of Water at Total Head in Feet								Max** Head	
	10'	20'	30'	40'	50'	60'	70'	80'		90'
3600 RPM	10,000	9200	8800	7500	6500	5600	4800	3500	2000	98 ft.

(**) Shut-off; to convert to psi, divide by 2.31

Maintenance

⚠ WARNING Make certain that unit is disconnected from power source before attempting to service or remove any components!

CLEANING

This unit has been designed to pump seawater laden with (up to 25%) abrasive particles like sand, stones, and shell fragments. It requires some special periodic maintenance to ensure maximum service life.

1. After each use pump must be thoroughly flushed and rinsed with fresh water to remove residual seawater.
2. When not in use pump should be stored away from damaging effects of seawater environment.

This unit has been designed with a removable volute enabling pump to be cleaned or unclogged easily. Remove

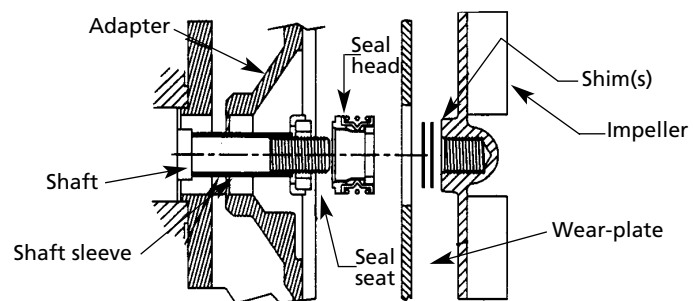

Figure 1 – Mechanical Seal

casing and volute as described under MECHANICAL SEAL REPLACEMENT. Remove any debris found inside of unit. After each use in a seawater environment, inside and outside of pump must be flushed with fresh water to remove any seawater residue.

MECHANICAL SEAL REPLACEMENT

Refer to figures 1 and 2.

NOTE: Always replace seal seat, (Ref. No. 6), seal head (Ref. No. 7), and shaft

sleeve (Ref. No. 8) to insure proper mating of mechanical seal components!

1. Unthread fasteners (Ref. No. 15) and remove casing (Ref. No. 13), o-ring (Ref. No. 5), and flapper valve (Ref. No. 12) from adapter (Ref. No. 3).
2. Unthread fasteners (Ref. No. 16) and remove volute (Ref. No. 11) from adapter.
3. Unscrew impeller (Ref. No. 10) from

For Repair Parts, contact dealer where pump was purchased.

Please provide following information:

- Model number
- Serial number (if any)
- Part description and number as shown in parts list

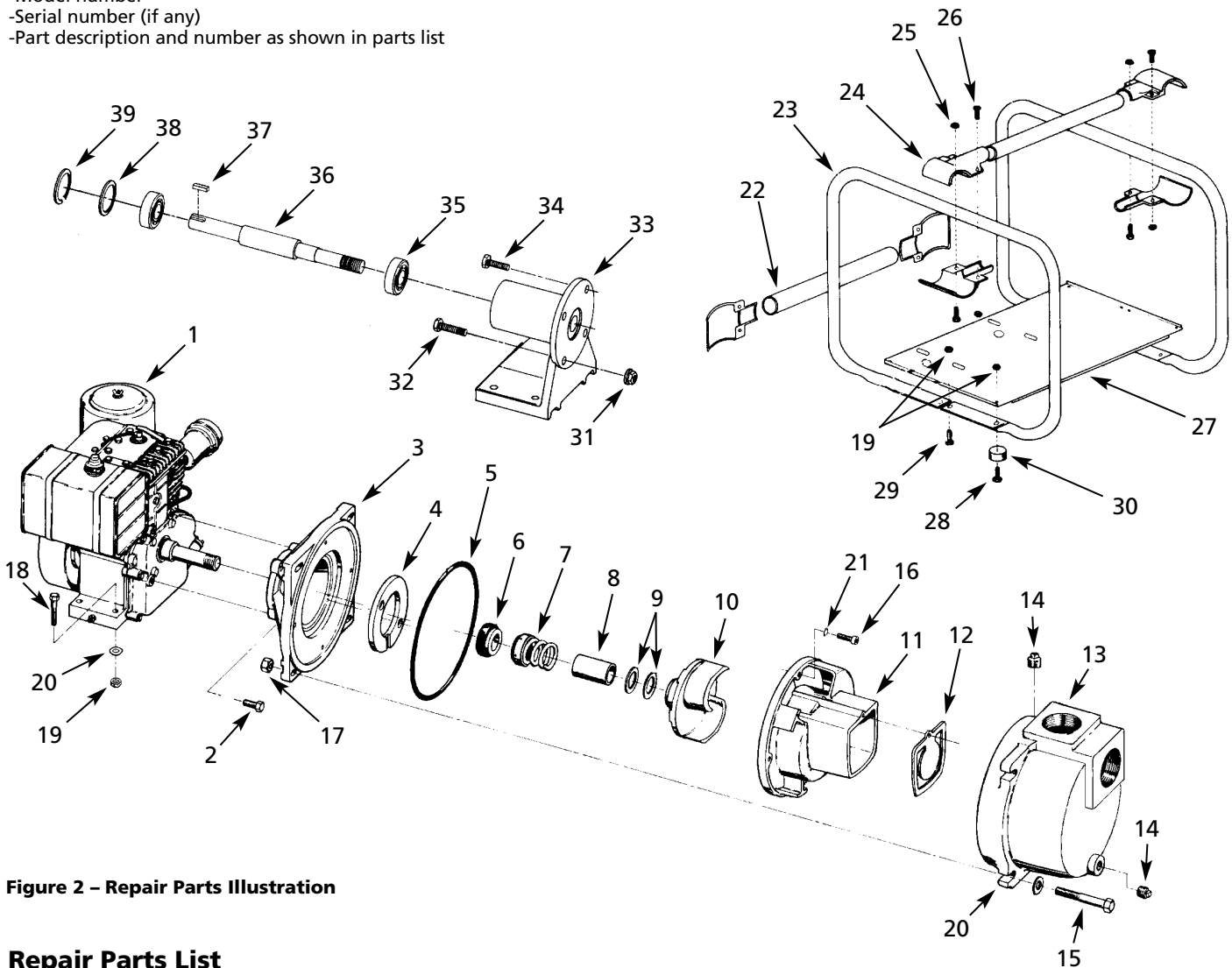

Figure 2 – Repair Parts Illustration

Repair Parts List

Ref. No.	Description	Part Number for Models:		Qty.
		316F-95	316F-99	
1	Engine	1639-036-00	—	1
2	Fastener	*	—	4
3	Adapter	1608-005-03	1608-005-03	1
4	Wear-plate	316F-061-00	316F-061-00	1
5	O-ring -Buna N	1610-000-00	1610-000-00	1
6&7	† Shaft seal assembly -Viton & Silicon carbide	1640-166-90	1640-166-90	1
8	Shaft sleeve	1483-000-00	1483-000-00	1
9	Impeller shim pkg. (one each 0.010", 0.020", 0.030")	1658-000-90	1658-000-90	1
10	Impeller	2760-010-01	2760-010-01	1
11	Volute	316F-150-01	316F-150-01	1
12	Flapper valve -Buna N	1609-002-00	1609-002-01	1
13	Casing	2111-001-02	2111-001-02	1
14	Pipe plug	*	*	2
15	Fastener	*	*	4

Model 316F-95 and 316F-99

Repair Parts List (continued)

Ref. No.	Description	Part Number for Models:		Qty.
		316F-95	316F-99	
16	Fastener	*	*	2
17	Nut	*	*	4
18	Fastener	*	—	4
19	Nut	*	—	12
20	Washer	*	—	8
21	Washer		*	2
22	Frame brace	1696-092-00	—	2
23	Outside rail	1696-099-00	—	2
24	Frame clamp	1696-091-00	—	8
25	Nut	*	—	8
26	Fastener	*	—	8
27	Frame base	1696-055-00	—	1
28	Fastener	*	—	4
29	Fastener	*	—	4
30	Rubber foot	1508-000-00	—	4
31	Nut	—	*	4
32	Fastener	—	*	2
33	Pedestal	—	1695-030-01	1
34	Fastener	—	*	2
35	Bearing	—	1695-031-00	2
36	Shaft	—	1695-001-00	1
37	Key	—	1517-000-00	1
38	Bearing shim pkg. (one each 0.005", 0.010", 0.020")	—	1696-008-90	1
39	Snap ring	—	1695-034-00	1
Δ	Pipe nipple	1696-044-00	1696-044-00	2
Δ	Suction strainer	1679-001-00	1679-001-00	1

(* Standard hardware item, available locally.

(† Available as set only.

(Δ) Not shown.

Maintenance (Continued)

shaft. Use a rubber mallet or soft block of wood to loosen impeller. Turn it counterclockwise. Remove impeller shim(s) (Ref. No. 9), shaft sleeve, and seal head from shaft. Remove wear-plate (Ref. No. 4) from adapter.

NOTE: To keep shaft from turning on engine-driven units, remove shroud from engine and hold flywheel in place.

4. Unthread fasteners (Ref. No. 2 or 32 & 34) and remove adapter from mounting face.
5. Push seal seat from adapter recess with a screwdriver.
6. Clean adapter recess before

inserting a new seal seat.

7. Carefully wipe seal face of new seal seat with a clean cloth.
8. Wet outside of rubber portion of seal seat with a light coating of soapy water.
9. Press new seal seat squarely into cavity in adapter. Use finger pressure only to avoid scratching seal seat. (This is a lapped surface and must be handled very carefully.)
10. After seal seat is in place, insure that it is clean and has not been marred.
11. Using a clean cloth, wipe shaft and make certain that it is perfectly clean.
12. Secure adapter on mounting face.

▲ CAUTION *Tighten fasteners **EVENLY** to avoid cocking rabbet on mounting face.*

13. Apply a light coating of soapy water to inside rubber portion of seal head and slide onto shaft sleeve. Slip shaft sleeve with seal head onto shaft with sealing face toward polished sealing surface of seal seat.

▲ CAUTION *Do not touch or wipe sealing face of seal head.*

14. Replace any impeller shim(s) removed in disassembly.
15. Screw impeller back in place, tightening until it is seated against shims and shaft sleeve.
16. Install wear-plate into rabbit in

2-Inch Self-Priming Dredging Pump

Maintenance (Continued)

adapter aligning fastener holes in adapter with clearance holes in wear-plate. Remount volute with fasteners.

NOTE: Do not over-tighten fasteners. Fasteners should be snug to eliminate play between adapter, wear-plate, and volute. Pressure developed from mounting casing to adapter will fix volute and wear-plate into position.

17. Refer to section entitled SHIM ADJUSTMENT at this time if shaft sleeve or any other parts listed therein have been replaced.

18. Inspect position of flapper valve to insure proper movement and seating.

19. Position o-ring on volute.

NOTE: Always inspect o-ring seal. Replace when cracked or worn. Wet o-ring with soapy water for ease of assembly.

20. Remount casing.

SHIM ADJUSTMENT

1. When installing a replacement impeller (Ref. No. 10), engine (Ref. No. 1), bearing assembly (Ref. Nos. 33, 35, 36, 38, 39), shaft sleeve (Ref. No. 8), adapter (Ref. No. 3), or volute (Ref. No. 11) it may be necessary to vary number of impeller shims (Ref. No. 9) that will be required. This is easily done by adding one 0.010" shim more than was removed, and reassembling pump as described in MECHANICAL SEAL REPLACEMENT section.

NOTE: When adding or removing shims, it is best to proceed with a 0.010" increment each time. Remove spark plug or disconnect and ground spark plug wire where applicable. While tightening fasteners (Ref. No. 16) turn shaft by hand and feel for shaft seizing. If shaft begins to seize before fasteners are completely tight, disassemble pump and remove one shim and repeat assembly.

2. Once having added one shim more

than original, ensure that volute and adapter are firmly fitted (check fasteners). When shaft turns freely add shims until it does strike then remove a 0.010" shim. This should allow proper clearance.

3. Proper running clearance for impeller should be as close as possible to volute without striking; maximum clearance is 1/32" (0.032").
4. Follow above procedure until proper clearance is obtained. This will ensure maximum performance.

IMPELLER, VOLUTE, AND WEAR-PLATE REPLACEMENT

Impeller (Ref. No. 10), volute (Ref. No. 11), and rear wear-plate (Ref. No. 4) are subject to wear by abrasive sand or sediment-laden liquids. If badly worn, all these parts can be replaced easily and pump thus restored to full efficiency.

NOTE: When clearance between impeller and volute exceeds 1/16" at face of impeller or 1/8" on outside diameter of impeller, it may be necessary to take corrective action. The increased clearance can cause lengthened priming and decreased capacity to your unit. If performance is satisfactory for your application, it is recommended that no corrective maintenance be performed regardless of what clearances may have developed on your unit. This is because increased clearances in themselves are not generally harmful to your pump. Normally, new pump clearances can be restored by simply shimming behind impeller. (Add shims Ref. No. 9). If impeller is badly worn it is recommended that impeller and volute be replaced. This is usually all that is required since only on unusually abrasive materials will wear-plate show deterioration. In these cases, follow instruction below for replacement and refer to Figure 2.

1. Disassemble pump for access as described in MECHANICAL SEAL REPLACEMENT, steps 1,2 and 3.

2. Replace parts as necessary.

NOTE: When replacing volute, impeller, or wear-plate, make sure flapper valve (Ref. No. 12) has been installed and is positioned correctly on volute.

NOTE: Before installing new parts, clean all mating surfaces thoroughly.

BEARING HOUSING SERVICE FOR MODEL 316F-99

1. Remove front pump assembly as described under Mechanical Seal Replacement (Steps 1, 2 & 3).
2. Disassemble bearing housing (Ref. No. 33) from pump adapter (Ref. No. 3) by removing fasteners (Ref. Nos. 31, 32, and 34).
3. Remove shaft bearing (Ref. No. 35) and shaft (Ref. No. 36) as an assembly by first removing snap ring (Ref. No. 39). Push shaft bearing assembly out of bearing housing by rapping on threaded end of shaft with a soft mallet, or block of wood and a hammer.
4. Ball bearings can now be removed from shaft.
5. If shaft bearings have been removed from shaft, replace by sliding bearing on shaft to shoulder. Replace shaft bearing assembly by sliding assembly into housing threaded end first. Push shaft bearing assembly completely in by gently tapping on keyway end of shaft with a soft mallet. Replace snap ring.
6. Reverse steps 1 thru 3 to reassemble pump.

IMPORTANT: After pump is assembled, it is necessary to rotate pump shaft by hand to check for striking of impeller. If striking or rubbing occurs, adjust impeller shims as required (See Shim Adjustment).